

## *APPLICATION GUIDE FOR FIBERRUNNER® CABLE ROUTING SYSTEM*

Versatile, Scalable Cable Protection in Data Centers  
and Central Offices



PANDUIT is a Technology  
Developer Partner for Storage  
Networking Hardware.

## The Need for Cable Routing

### ***What is a Cable Routing System?***

A Cable Routing System is a collection of channels, fittings, and mounting brackets that can be assembled to create a structure that protects fiber optic and high performance copper data cabling from physical damage that can disrupt or cut off signal transmission. It also provides a versatile, scalable pathway that reduces the costs associated with maintaining existing network operations and implementing new services. Cable Routing Systems are not just a means of containing cabling deployed in data centers or central offices. They are an integral component of the overall cable management system needed to ensure optimum network performance.

### ***Can you afford improper cable routing?***

Network problems can cost large companies hundreds of thousands of dollars. A recent study found that companies can lose as much as 3.6% of their annual revenues to network downtime and service degradation<sup>1</sup>. Contributing to this is improperly routed or unprotected fiber optic cable, which is susceptible to various types of damage. Crushing, pinching, or microbending can result in impeded signal transmission and cable breakage. Bend radius violations, or macrobending, in fiber optic and copper cables can increase attenuation affecting overall system performance and cause fatigue leading to long-term signal failure.

Therefore, improperly routed cables are at risk of being damaged and can result in service interruption and downtime. Identifying, testing, removing and replacing a damaged cable is costly in terms of labor and network service interruptions.

A properly designed and installed Cable Routing System carries cabling along a logical route to minimize bends and optimize cable lengths while providing easy access to make moves, adds, or changes. A well-engineered and installed Cable Routing System costs a fraction of the potential downtime losses and day-to-day operating costs over the life of the network, thereby reducing the total cost of ownership.

### ***The Value of the PANDUIT Solution***

***Always a leader in providing customers with solutions, PANDUIT offers a complete range of cable routing, management, connectivity and cabling products to meet today's data center and service provider central office needs.***

***The PANDUIT® FIBERRUNNER® Cable Routing System ensures maximum network reliability and reduced cost of ownership. Robust, highly engineered components with integral bend radius control surfaces can be configured to meet virtually any network application to provide optimum cable protection and assure network performance. Fast and easy to deploy, this scalable cable routing solution reduces installation cost and speeds implementation of new services.***

<sup>1</sup>Infonetics Research, The Cost of Enterprise Downtime, North America 2004.



## FIBERRUNNER® Cable Routing System Benefits

**Ensure network reliability** with a complete solution that protects cables from physical damage while maintaining signal integrity and delivering reliable network performance.

- Strong, rigid channel and cover profiles protect cables from impact damage
- Directional fittings provide integral bend radius control and smooth surfaces, protecting cables from bends and snags

**Reduce installation costs** with innovative snap-together couplers, mounting brackets, and accessories that require minimum use of tools and small fasteners to assemble. These components are part of a comprehensive system that provides lower installed cost.

- **QUIKLOCK™** Couplers allow components to be assembled in less than five seconds without the use of tools
- Covers snap on to channels and fittings, eliminating the need for tools or small fasteners
- **QUIKLOCK™** Mounting Brackets allow channel to be attached to infrastructure without drilling or using small, loose fasteners

**Enable future growth** or modification with a complete offering of sizes, fittings, and mounting options that make this system one of the most versatile cable routing solutions available.

- Wide range of directional fittings allows the system to meet virtually any network configuration
- Broad assortment of **QUIKLOCK™** Mounting Brackets allow the system to be mounted to any type of infrastructure

**Lower cost of ownership** through a combination of unique features and standards compliance.

- Snap-on, hinged channel covers and split fitting covers allow easy access to cables without fully removing covers, thereby reducing time required to make moves, adds, and changes
- Compliance with stringent industry standards including UL 2024A and NEBS GR-63 (ensures that system features and functions will withstand regular use and perform over the lifetime of the installation)
- Solid, maintenance-free, non-metallic channel and fitting construction will last the life of the system

**PANDUIT® FIBERRUNNER® Cable Routing System dramatically reduces installation time – by installing up to three times faster than traditional bolt together systems and up to two times faster than competitive modular systems.**

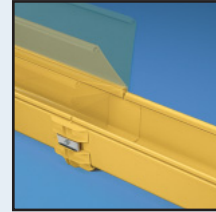

Innovative Snap-On Hinged Covers attach without use of tools or small fasteners.

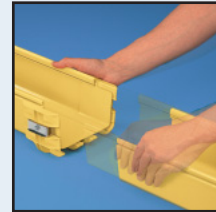

**QUIKLOCK™** Coupler provides fast connection between components without need for tools or small fasteners.

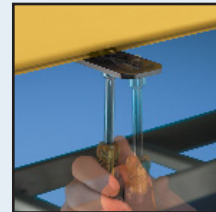

**QUIKLOCK™** Mounting Brackets speed implementation.

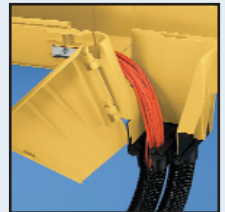

Spill-out fittings provide bend radius control to protect cables.



Wide range of directional fittings provides flexibility.

|  |                      |                            |                     |
|--|----------------------|----------------------------|---------------------|
|  |                      |                            |                     |
|  | Bolt Together System |                            |                     |
|  |                      | Competitive Modular System |                     |
|  |                      |                            | FIBERRUNNER® System |

**Installation Labor Cost Comparison**



## Data Center Cable Pathway Roadmap

Below is a typical data center *FIBERRUNNER*<sup>®</sup> Cable Routing System application. The pathway is configured to route and protect cabling between the Main Distribution Area (MDA) and the Equipment Distribution Areas (EDA)<sup>2</sup>. Key features include the innovative *QUIKLOCK*<sup>™</sup> Coupler that is used to securely join system components, a wide range of spill-out options to transition cable into the cabinets, and a complete offering of directional fittings and channel sizes.

The *FIBERRUNNER*<sup>®</sup> Cable Routing System integrates with a complete offering of *PANDUIT* Racks and Cable Management Systems to help manage higher cable densities as well as *STRUCTUREDGROUND*<sup>™</sup> Systems designed to protect all elements of the data center.

For more information, refer to *PAN-NET*<sup>®</sup> Network Solutions Catalog, SA-NCCB34, or visit [www.panduit.com](http://www.panduit.com).

**Transitions to Other Channel Sizes**  
(See detail on page 6.)

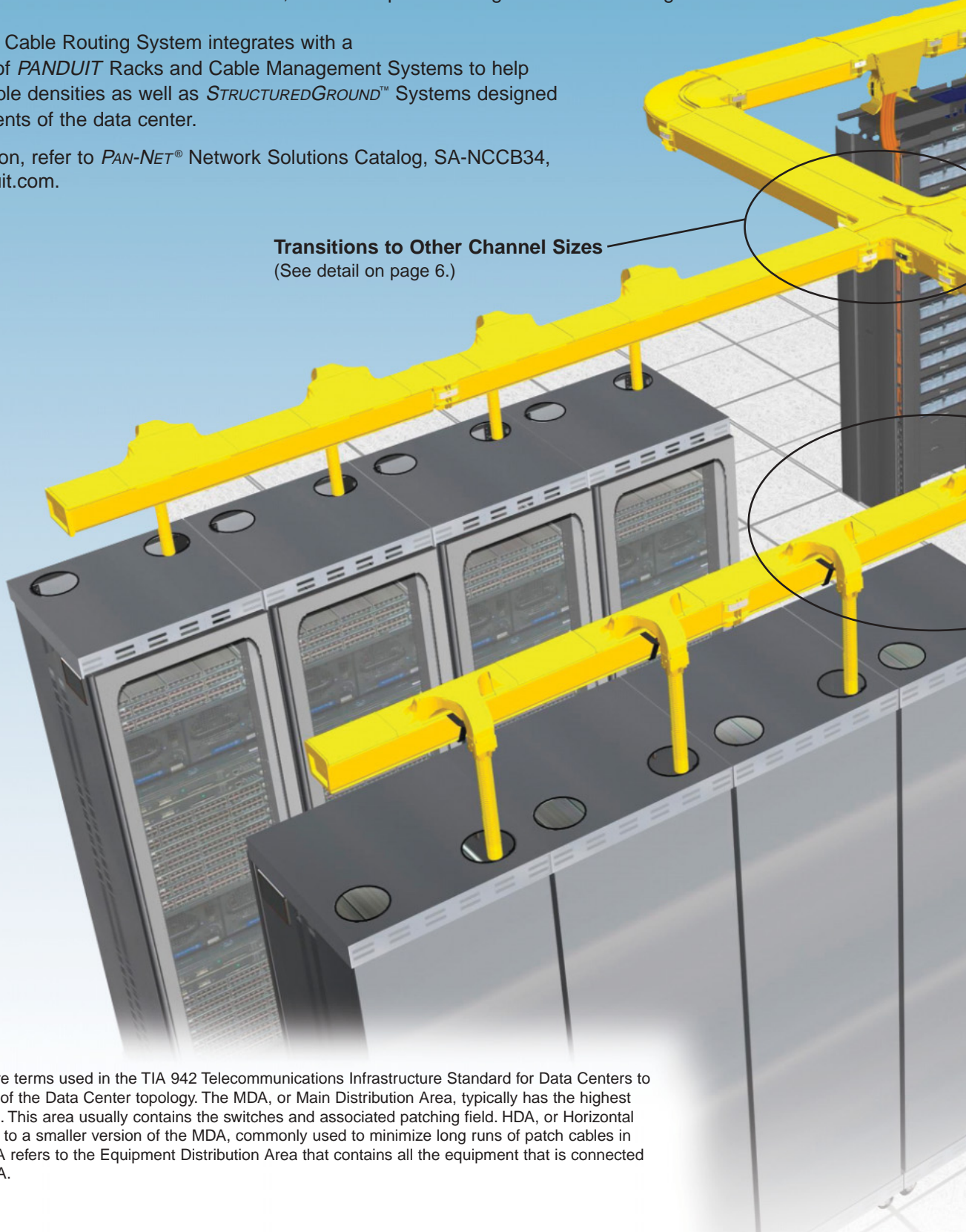

<sup>2</sup>MDA, EDA and HDA are terms used in the TIA 942 Telecommunications Infrastructure Standard for Data Centers to describe primary areas of the Data Center topology. The MDA, or Main Distribution Area, typically has the highest concentration of cabling. This area usually contains the switches and associated patching field. HDA, or Horizontal Distribution Area, refers to a smaller version of the MDA, commonly used to minimize long runs of patch cables in larger data centers. EDA refers to the Equipment Distribution Area that contains all the equipment that is connected back to the MDA or HDA.

**Routing Cables In and Out of the MDA**  
(See detail on page 6.)

**QUIKLock™ Coupler Feature**



Patented QUIKLock™ Coupler speeds assembly of system components without the need for tools or small fasteners.

**Protecting Cable Transitioning to EDA Cabinets**  
(See detail on page 6.)

**Typical Application Configuration:  
Plan View of Distribution and Feeder Design**

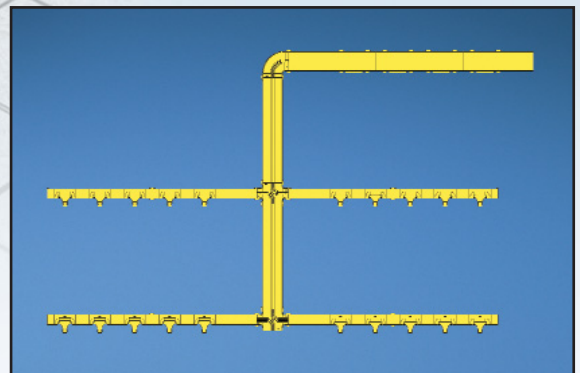

The Distribution and Feeder configuration is the basic, economic layout used to route cables out of the MDA. A higher capacity Distribution Run is used to supply the feeders that route cables out to the cabinets in the EDA. The Feeders in turn are positioned over the cabinet line ups to create a pathway that will provide efficient transitions to the vertical cable management areas of the cabinets and not interfere with Cold Aisle cooling air flow.



## Data Center Roadmap Details

(See Roadmap on pages 4 and 5.)

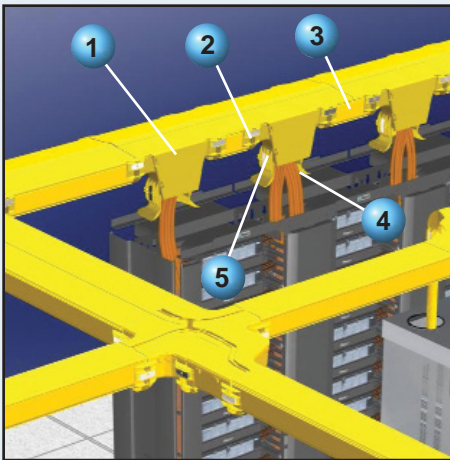

### A. Routing Cable Out of the MDA

The *FIBERRUNNER*® Cable Routing System includes vertical tee fittings for routing cables out of the MDA racks. These fittings can be sized for the anticipated cable capacity and positioned directly above the vertical cable managers to create as direct a pathway as possible.

Components used in this detail:

- |                                       |  |
|---------------------------------------|--|
| 1. FRVT12X4 Vertical Tee              | 4. FRTR6X4 3-Sided Bend Radius Control Trumpet |
| 2. FRBC12X4 <i>QUIKLOCK</i> ™ Coupler | 5. FRBC6X4 <i>QUIKLOCK</i> ™ Coupler           |
| 3. FR12X4 Channel                     |  |

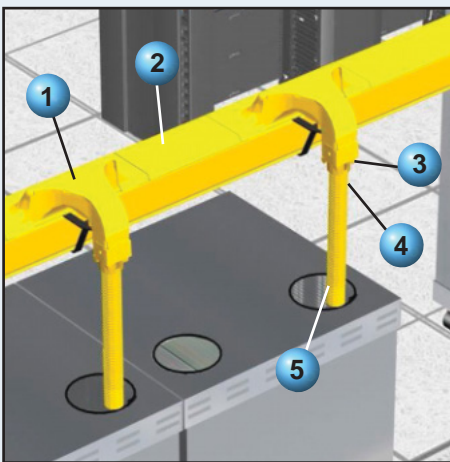

### B. Transitioning Cables Into the EDA Cabinets

The *FIBERRUNNER*® Cable Routing System offers a wide variety of spill-out options to provide safe, accessible transitions to the cabinets in the EDA. Spill-over fittings, which can be attached to any straight section of channel, can be used at the initial installation or retrofit into existing configurations as the network changes or grows.

Components used in this detail:

- |                                     |   |
|-------------------------------------|---|
| 1. FRSP Spill-Over Junction         | 4. FIDT2X2 Transition to 1.5" ID Slit Corrugated LoomTubing |
| 2. FR6X4 Channel                    | 5. CLT150F 1.5" ID Slit Corrugated Loom Tubing              |
| 3. FBC2X2 <i>QUIKLOCK</i> ™ Coupler |   |

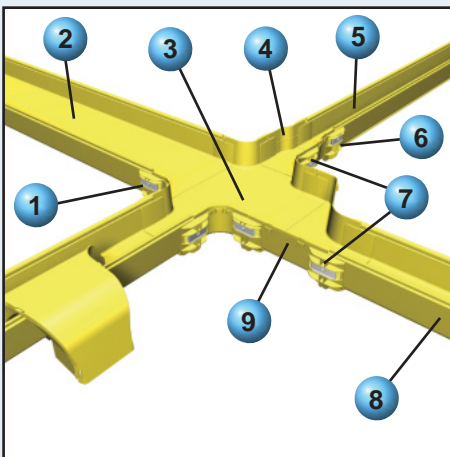

### C. Transitions to Other Channel Sizes

Reducer fittings are available to provide a method of transitioning between different *FIBERRUNNER*® Cable Routing System sizes. In addition, 12x4 tee fittings and 4-way crosses with integral 6x4 exits can be used to create feeder runs.

Components used in this detail:

- |   |  |
|---|--|
| 1. FRBC12X4 <i>QUIKLOCK</i> ™ Coupler     | 6. FRBC4X4 <i>QUIKLOCK</i> ™ Coupler                     |
| 2. FR12X4 Channel                         | 7. FRBC6X4 <i>QUIKLOCK</i> ™ Coupler                     |
| 3. FRFWC12X4W6 4-Way Cross with 6x4 Exits | 8. FR6X4 Channel   |
| 4. FRRF6FR4 6x4 to 4x4 Reducer Fitting    | 9. FRRF126R 12x4 to 6x4 Transition Right Reducer Fitting |
| 5. FR4X4 Channel                          |  |

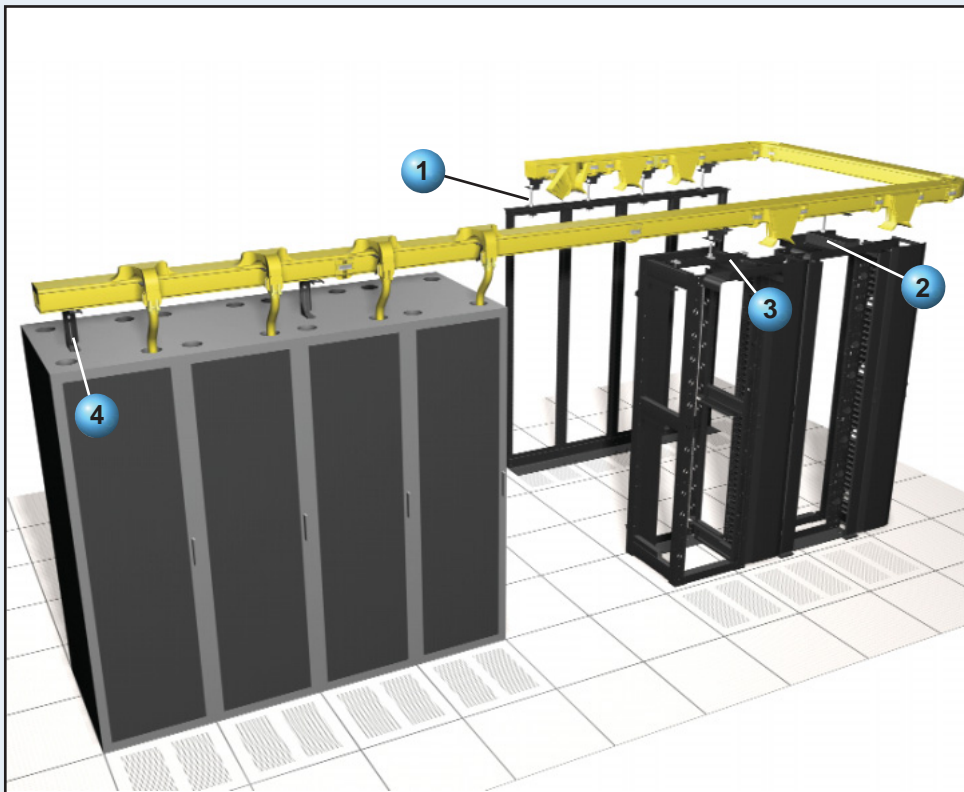

## D. Supporting the System Directly on Racks and Cabinets

When an overhead infrastructure is not available, there are several options that allow the *FIBERRUNNER*® Cable Routing System to be mounted to the tops of *PANDUIT*® *NETFRAME*® Racks, 4-Post Racks, EIA/TIA racks and *PANDUIT*® *NET-ACCESS*™ Cabinets. Components used in this detail:

1. FEIAB58 EIA/TIA Threaded Rod Bracket
2. FRRMBNF58 *NETFRAME*® Rack Bracket
3. FR4PRB58 4-Post Rack Bracket
4. FR6ACAB Adjustable Cabinet Bracket

(See pages 12 – 13 for full range of mounting brackets.)

Refer to *PAN-NET*® Network Solutions Catalog, SA-NCCB34 or [www.panduit.com](http://www.panduit.com) for more information about *PANDUIT*® *NETFRAME*® Rack System, *PATCHRUNNER*™ Vertical Cable Management Rack System, 4-Post Racks and *PANDUIT*® *NET-ACCESS*™ Cabinets.

## Telecommunication Room Roadmap

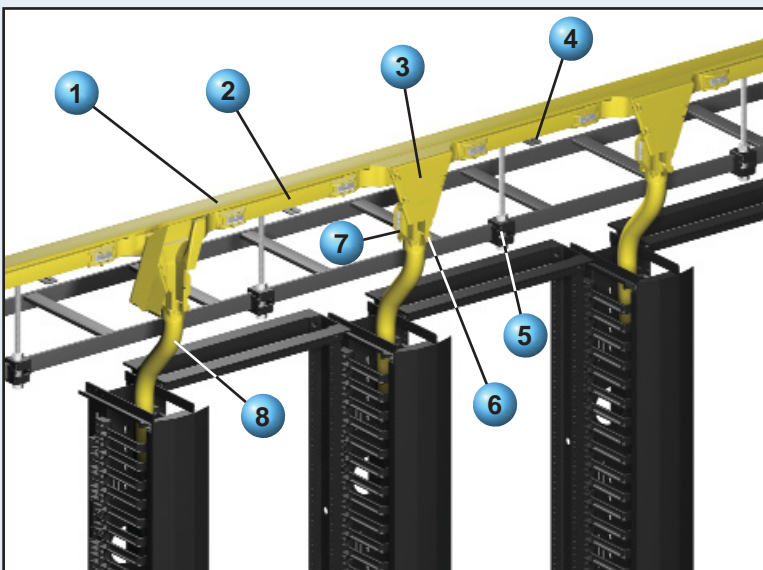

### Telecommunications Rooms

As an alternative to inner duct or exposed cabling on ladder rack or wire basket tray, the 2x2 *FIBERRUNNER*® Hinged Duct can be used to route and protect small amounts of fiber cable along racks. Vertical Tees with integral hinged doors provide access and protection. Snap together transitions to slit corrugated loom tubing and *QUIKLOCK*™ Couplers reduce installation time. Components used in this detail:

1. HC2 *FIBERRUNNER*® Hinged Cover
2. HS2X2 *FIBERRUNNER*® Hinged Channel
3. FVTHD2X2 Vertical Tee
4. FTRBN12 New Threaded Rod Bracket
5. F2PCLB12 2-Piece Clamping Ladder Rack Bracket
6. FIDT2X2 Transition to 1.5" ID Slit Corrugated Loom Tubing
7. FBC2X2 *QUIKLOCK*™ Coupler
8. CLT150F 1.5" Slit Corrugated Loom Tubing

*PANDUIT* offers a complete line of structured cabling products for Telecommunication Room applications including Rack Systems, Vertical and Horizontal Cable Management Systems, Grounding and Power Connectors, Patch Panels, *DPoE*™ Power Patch Panels, Fiber Optic Cable and Fiber Optic Connectivity Products.

For more information, see *PAN-NET*® Network Solutions Catalog, SA-NCCB34, or visit [www.panduit.com](http://www.panduit.com).



## ***Service Provider Central Office Cable Pathway Roadmap***

In this application, the *FIBERRUNNER*® Cable Routing System is used to segregate fiber optic jumper cables from all of the other cables routed in the central office. Key features include innovative Snap-On Hinged Covers, Split Fitting Covers, and Vertical Tees with integral hinged doors. In addition, the system offers a wide variety of transitions from horizontal runs to the vertical cable managers on Network Element Bays. These features provide accessibility and protection, reducing the time required for moves, adds, and changes.

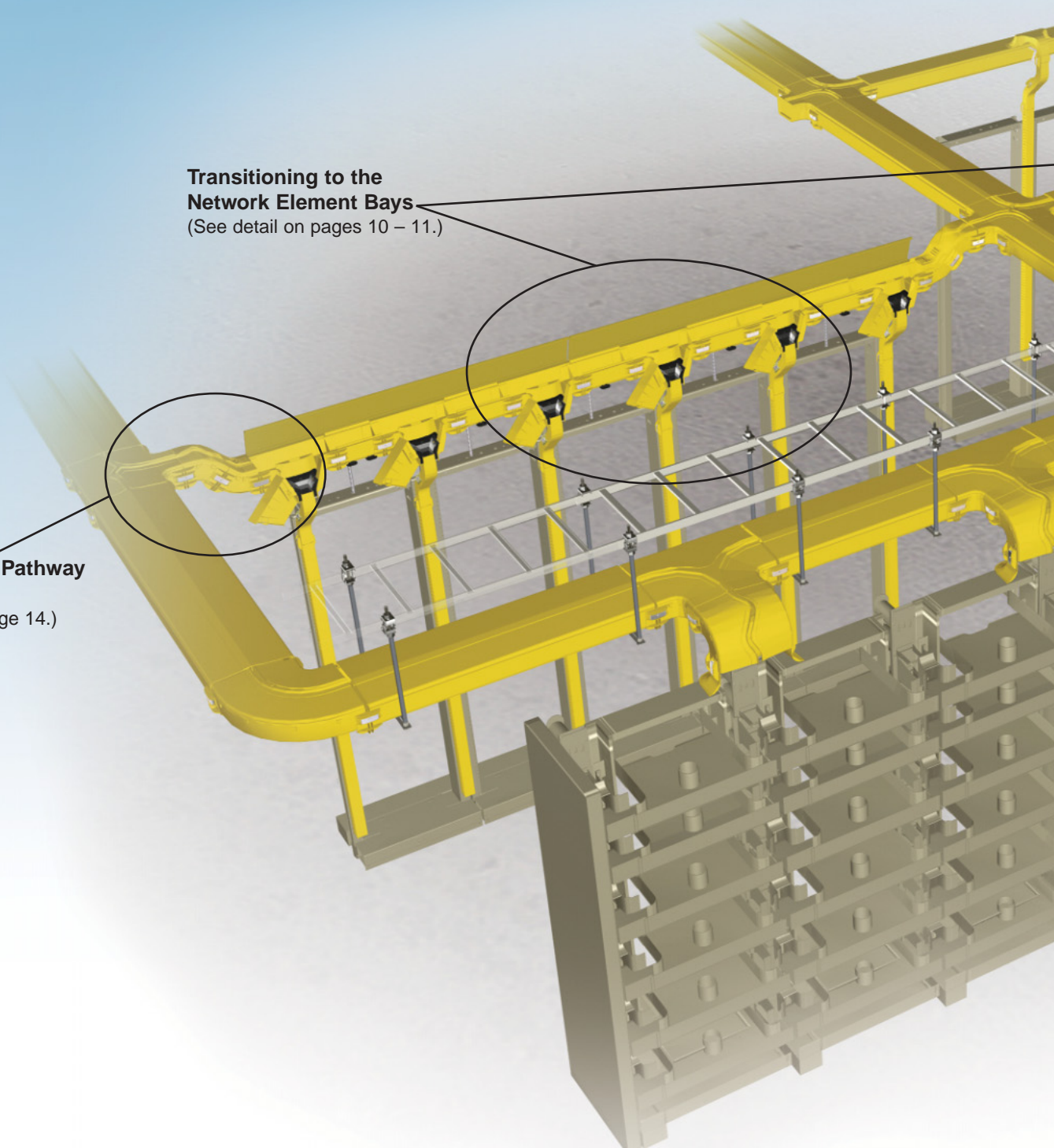

**Transitioning to the  
Network Element Bays**  
(See detail on pages 10 – 11.)

The image shows a 3D perspective view of a yellow cable routing system. It consists of horizontal and vertical channels connected by various fittings. Two circular callouts highlight specific transition points. One callout points to a corner fitting, and the other points to a vertical transition point where a cable enters a vertical channel. Below the routing system is a grey metal rack structure with multiple rows of ports.

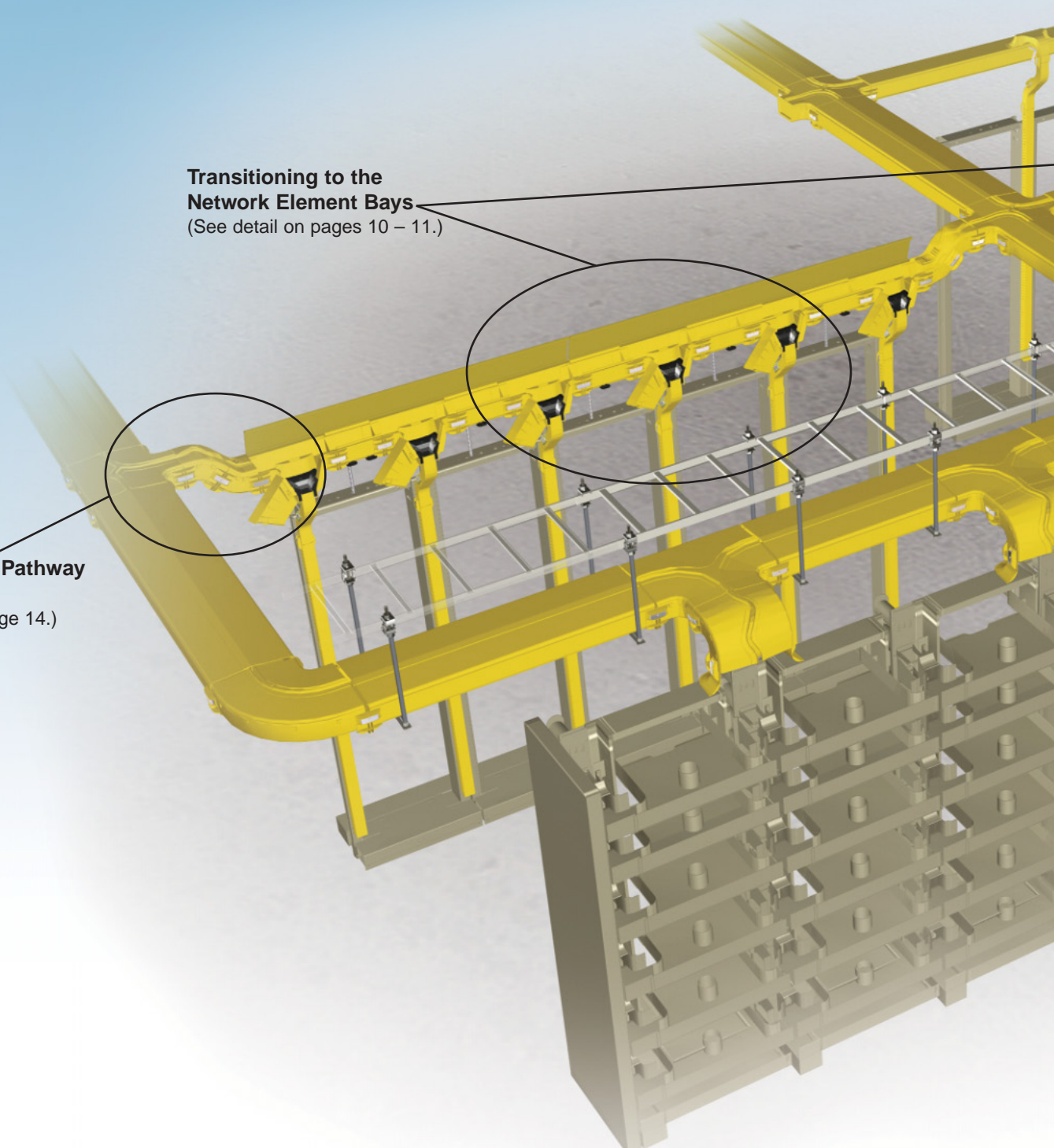

**Protecting the Pathway  
with Covers**  
(See detail on page 14.)

This callout points to a specific corner fitting in the yellow cable routing system, highlighting the snap-on hinged cover that protects the pathway at the corner.



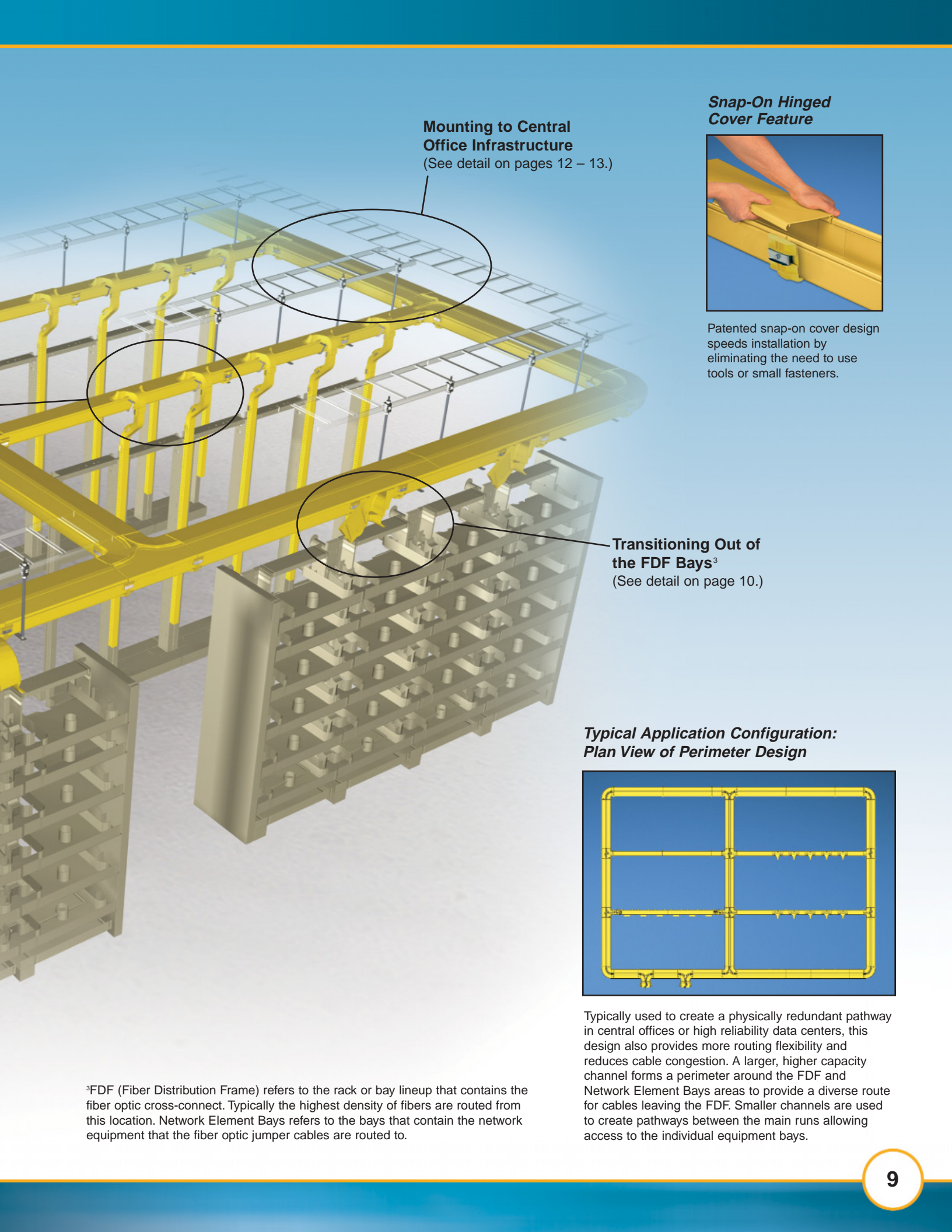

**Mounting to Central Office Infrastructure**  
(See detail on pages 12 – 13.)

**Snap-On Hinged Cover Feature**



Patented snap-on cover design speeds installation by eliminating the need to use tools or small fasteners.

**Transitioning Out of the FDF Bays<sup>3</sup>**  
(See detail on page 10.)

**Typical Application Configuration: Plan View of Perimeter Design**

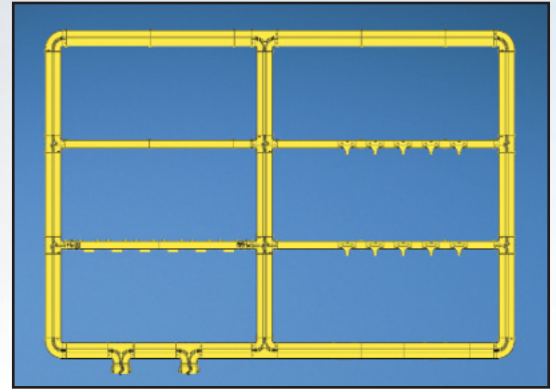

Typically used to create a physically redundant pathway in central offices or high reliability data centers, this design also provides more routing flexibility and reduces cable congestion. A larger, higher capacity channel forms a perimeter around the FDF and Network Element Bays areas to provide a diverse route for cables leaving the FDF. Smaller channels are used to create pathways between the main runs allowing access to the individual equipment bays.

<sup>3</sup>FDF (Fiber Distribution Frame) refers to the rack or bay lineup that contains the fiber optic cross-connect. Typically the highest density of fibers are routed from this location. Network Element Bays refers to the bays that contain the network equipment that the fiber optic jumper cables are routed to.

## Service Provider Roadmap Details

(See Roadmap on pages 8 and 9.)

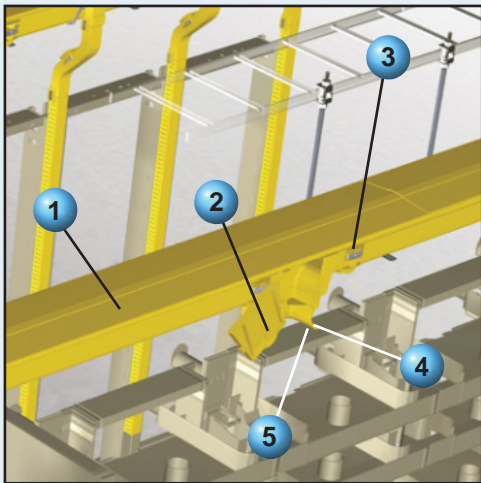

### A. Transitioning Cable Out of the FDF Bays

For fiber optic jumper cables routed in and out of the Fiber Distribution Frame, high capacity vertical tee fittings are positioned directly above the vertical fiber slack managers providing as direct a pathway as possible. Vertical tee fittings are typically positioned with doors facing the maintenance aisle to provide access to the cables.

Components used in this detail:

1. FR12X4 Channel and FRVC12 Cover
2. FRVC12X4 Vertical Tee
3. FRBC12X4 QUIKLOCK™ Coupler
4. FRBC6X4 QUIKLOCK™ Coupler
5. FRTR6X4 3-Sided Bend Radius Control Trumpet

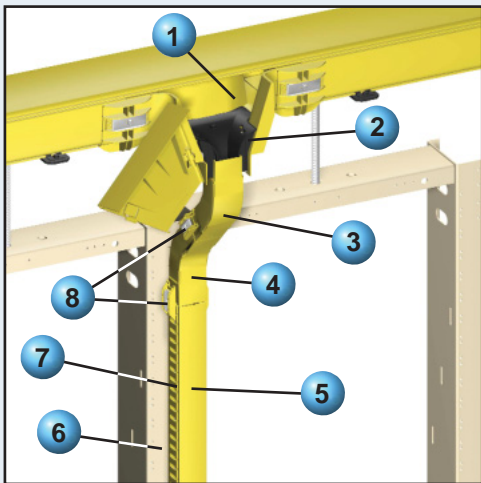

### B. Transitioning Cables into the Network Element Bays

In service provider environments the preference is to completely enclose the fiber optic jumper cables transitioning from horizontal runs down to the equipment in the Network Element Bays. There are several methods that can be used depending upon the position of the horizontal run relative to the Network Element Bays. Described below is a component configuration commonly used:

1. FRVT6X4 or FRVT4X4 QUIKLOCK™ Vertical Tee
2. FRLPR42 Low Profile Reducer
3. FOV452X2 Outside Vertical 45° Angle Fitting
4. FIV452X2 Inside Vertical 45° Angle Fitting
5. HC2 FIBERRUNNER® Hinged Cover
6. FZBA1.5X4 Adjustable "Z" Bracket (not visible)
7. H2X2 FIBERRUNNER® Hinged Slotted Channel
8. FBC2X2 QUIKLOCK™ Coupler

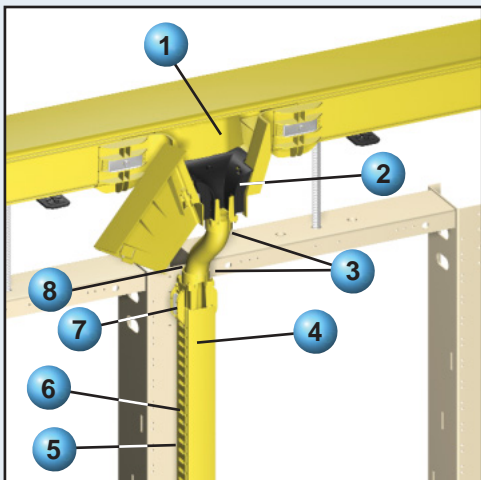

Another option is to use flexible corrugated loom tubing from the vertical tee fitting to the 2x2 slotted hinged duct. This approach eliminates the time required to position and secure multiple individual fittings to create a protected pathway. Components used in this detail include:

1. FRVT6X4 or FRVT4X4 QUIKLOCK™ Vertical Tee
2. FRLPR42 Low Profile Reducer
3. FIDT2X2 Transition to 1.5" ID Slit Corrugated Loom Tubing
4. HC2 FIBERRUNNER® Hinged Cover
5. FZBA1.5X4 Adjustable "Z" Bracket
6. H2X2 FIBERRUNNER® Hinged Slotted Channel
7. FBC2X2 QUIKLOCK™ Coupler
8. CLT150F 1.5" ID Slit Corrugated Loom Tubing



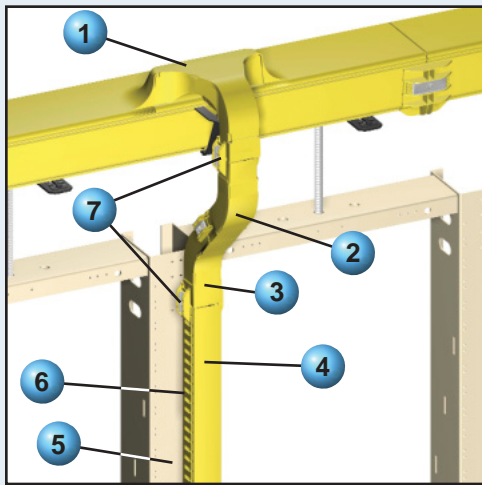

### Transitioning Cables into the Network Element Bays (continued from previous page)

Spill-over fittings can also be used to create exits over the Network Element Bays. These fittings can be used during initial installation or as a retrofit when a line-up is extended or new equipment is added to the network. In the central office the preference is to completely enclose the fiber optic jumper cables transitioning from horizontal runs down into the equipment in the Network Element Bays.

Components used in this detail include:

1. FRSP Spill-Over
2. FOV452X2 Outside Vertical 45° Angle Fitting
3. FIV452X2 Inside Vertical 45° Angle Fitting
4. HC2 *FIBERRUNNER*® Hinged Cover
5. FZBA1.5X4 Adjustable “Z” Bracket (not visible)
6. H2X2 *FIBERRUNNER*® Hinged Slotted Channel
7. FBC2X2 *QUIKLOCK*™ Coupler

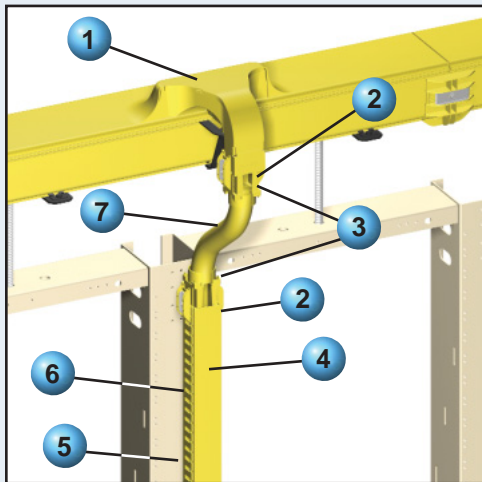

Another option is to use flexible corrugated loom tubing from the spill-over fitting to the 2x2 slotted hinged duct. This approach eliminates the time required to position and secure multiple individual fittings to create a protected pathway.

Components used in this detail include:

1. FRSP Spill-Over
2. FBC2X2 *QUIKLOCK*™ Coupler
3. FIDT2X2 Transition to 1.5" ID Slit Corrugated Loom Tubing
4. HC2 *FIBERRUNNER*® Hinged Cover
5. FZBA1.5X4 Adjustable “Z” Bracket (not visible)
6. H2X2 *FIBERRUNNER*® Hinged Slotted Channel
7. CLT150F 1.5" Slit Corrugated Loom Tubing

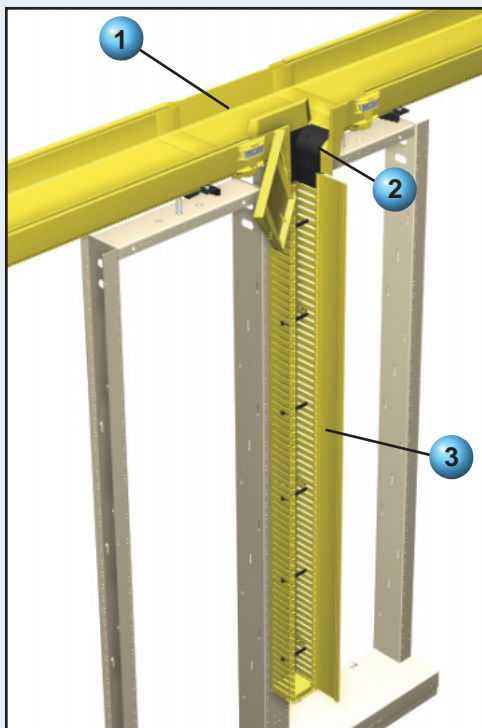

### C. Transitioning Cables into High Capacity Network Element Bays

To provide a secure, accessible pathway to high density Network Element Bays, the FRHD4KT 4x4 slotted hinged duct kit can be used. The innovative, hinged cover opens easily from either side without having to be removed from the duct, allowing access to cables, reducing the time needed to make changes.

Components used in this detail include:

1. FRVT12X4 Vertical Tee
2. FRLPR64 6x4 to 4x4 Low Profile Reducer
3. FRHD4KT 4x4 Hinged Duct Vertical Cable Management Kit

| Cable Capacity Comparison | 2x2 Slotted Hinged Duct | 4x4 Slotted Hinged Duct |
|---------------------------|-------------------------|-------------------------|
| 2mm Fiber Optic Cable     | 349                     | 1499                    |
| 1.6mm Fiber Optic Cable   | 546                     | 2343                    |

The FRHD4KT Kit contains:

- 6' length, 4x4 Hinged Slotted Channel
- 6' length, 4" Snap-On Hinged Cover
- Adapter to fit end of 4x4 or 6x4 *QUIKLOCK*™ Vertical Tee or 6x4 to 4x4 Low Profile Reducer Fitting
- Three Adjustable “Z” Brackets, End Cap and Wire Retainers

## System Mounting Components

The *FIBERRUNNER*® Cable Routing System provides a wide range of mounting brackets that secure the system to virtually any data center or service provider infrastructure. *QUIKLOCK*™ Mounting features reduce assembly time and speed implementation.

**Attaching the System to Common Infrastructures Including Auxiliary Framing Bar, Ladder Rack (Cable Runway), Threaded Rod, Under-Floor Pedestals and Strut.**

|   |                                       |                                   |
|---|---------------------------------------|-----------------------------------|
|   |                                       |                                   |
| <p><b>Auxiliary Framing Support</b></p> | <p><b>Ladder Rack Support</b></p>     | <p><b>Ladder Rack Support</b></p> |
|   |                                       |                                   |
| <p><b>Top Support 'C' Bracket</b></p>   | <p><b>Top Support 'C' Bracket</b></p> | <p><b>Under-floor Support</b></p> |

**Attaching the System Directly to Racks and Cabinets.**

|   |   |                                     |
|---|---|-------------------------------------|
|   |   |                                     |
| <p><b>Mounting to PANDUIT 4-Post Rack</b></p> | <p><b>Mounting to PANDUIT® NETFRAME® Rack</b></p> | <p><b>Mounting to EIA Racks</b></p> |



**QUIKLOCK™  
Mounting Feature**

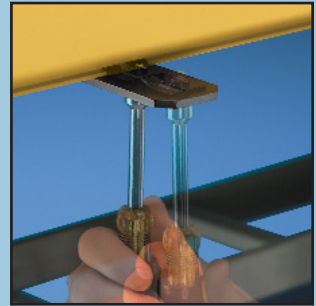

Innovative QUIKLOCK™ Mounting Slide Clamps allow fast assembly with a standard 7/16" nut driver.

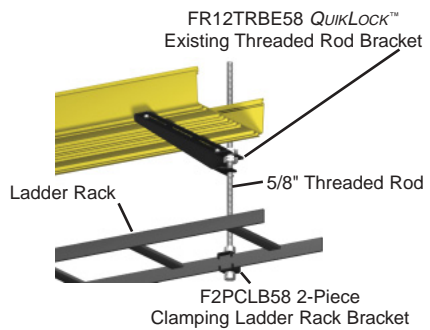

**Ladder Rack Support**

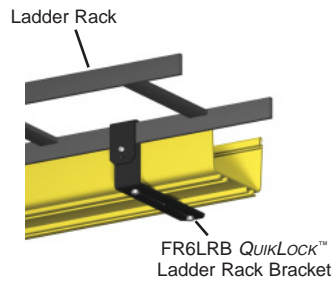

**Ladder Rack Support**

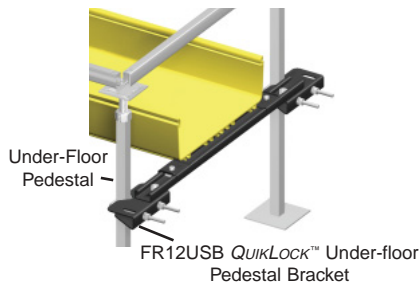

**Under-Floor Support**

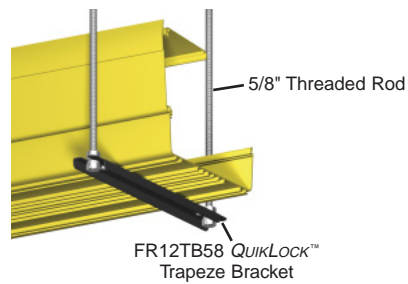

**Trapeze Supports**

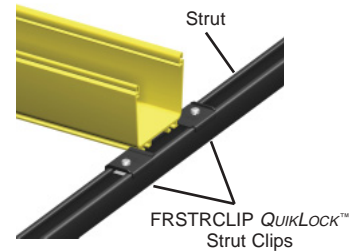

**Mounting to Strut Systems**

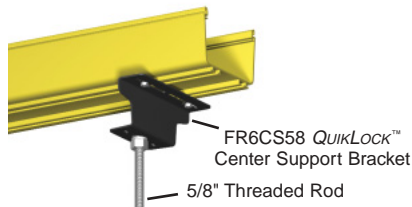

**Center Support**

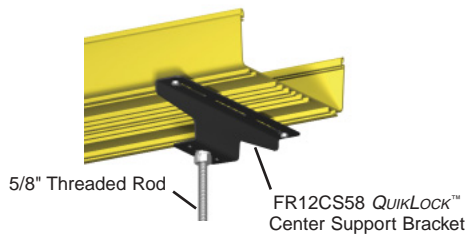

**Center Support**

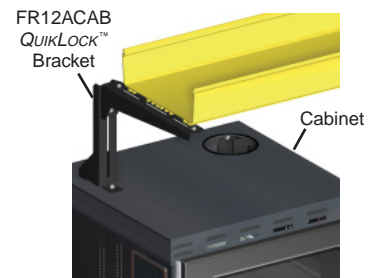

**Mounting to  
Cabinet Tops**

## System Cover Components

The *FIBERRUNNER*<sup>®</sup> Cable Routing System provides a comprehensive offering of snap-on covers for channels and fittings. Covers provide protection, enhancing network reliability while enabling ease of access to cables and lowering the cost of ownership.

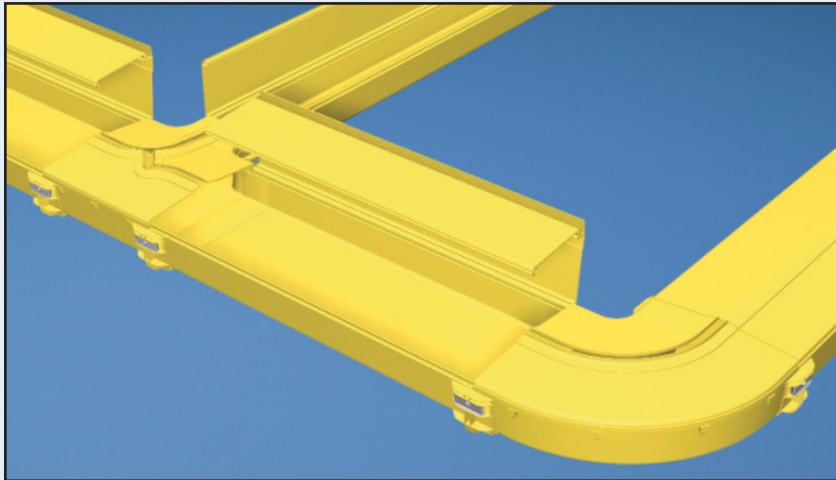

### Protecting the Pathway with Covers

The *FIBERRUNNER*<sup>®</sup> Cable Routing System has a complete assortment of unique, snap-on hinged channel covers and snap-on split fitting covers to provide the highest degree of cable protection while still allowing easy access.

Snap-on hinged covers are available for all channel sizes.

Optional snap-on split hinged covers are available for the 4x4 and 6x4 *FIBERRUNNER*<sup>®</sup> channels to provide a low profile hinged cover solution.

In height restricted applications, the 12x4 snap-on hinged cover incorporates a unique secondary hinge that minimizes the space required to access the channel.

2x2 snap-on hinged cover can be opened from either side maximizing access to the channel.

Optional snap-on split fitting covers can be ordered separately for most fittings with the exception of the inside vertical directional fittings which are supplied with covers.



Snap-On Hinged Solid Cover

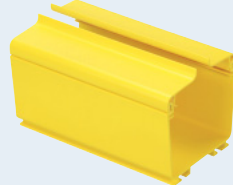

Snap-On Split Hinged Cover



Snap-On Split Fitting Covers

### System Sizes

The *FIBERRUNNER*<sup>®</sup> Cable Routing System is offered in four channel sizes providing a range of cable capacity.



12x4 *FIBERRUNNER*<sup>®</sup> Channel Profile



6x4 *FIBERRUNNER*<sup>®</sup> Channel Profile

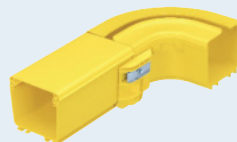

4x4 *FIBERRUNNER*<sup>®</sup> Channel Profile



2x2 *FIBERRUNNER*<sup>®</sup> Channel Profile

### Color Options

The system is available in three standard colors to meet the need for data center aesthetics and to differentiate between different types of cables routed within a data center or service provider central office.



**Yellow** – Typical color used to denote a single mode fiber optic cable route.



**Black** – Used in data centers in which aesthetics are more important.



**Orange** – Typically used to denote multimode fiber.



## Design Tools

The *FIBERRUNNER*® Cable Routing System is offered with two different Design Tools that allow accurate system drawings to be created which speeds overall system design, specification and implementation. Both a VISIO\* and AutoCAD\*\* version are available as free downloads from: [www.panduit.com/products/selectiontools](http://www.panduit.com/products/selectiontools).

### *FIBERRUNNER*® Design Tool for AutoCAD\*\* includes:

- Drag-and-Drop Functionality
- Ability to design in 2D or 3D
- Versions Compatible with AutoCAD\*\* and AutoCAD\*\* LT
- Automated BOM Generator

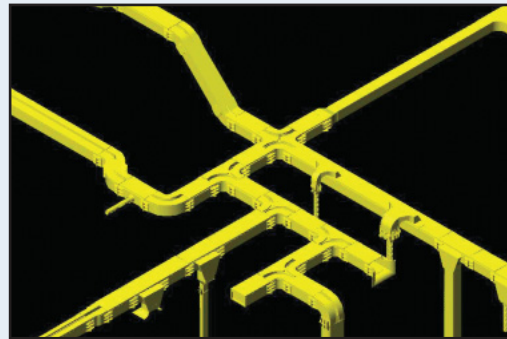

### Data Center VISIO\* Layout Tool includes:

- Drag-and-Drop Functionality
- Ability to design in 2D (stencils for three different views are provided)
- Automated BOM Generator

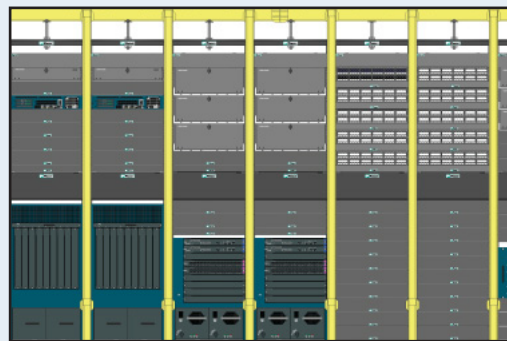

\*VISIO is a registered trademark of Microsoft Corporation in the United States and/or other countries.

\*\*AutoCAD is a registered trademark of Autodesk, Inc.

## *PANDUIT*® *FIBERRUNNER*® Cable Routing System Application Standards

|   |   |
|---|---|
| <p><b>NEBS GR-63 CORE, Level 3 Compliance as tested by NTS</b></p> <p>Network Equipment Building Systems (NEBS) was developed by Bellcore, now known as Telcordia Technologies, and is currently maintained by Telcordia Technologies. NEBS was developed to standardize requirements for Central Office Equipment and to develop criteria for personal safety, protection of property, and operational continuity.</p> | <p><b>NEBS Level 3 Criteria is the minimum of environmental compatibility needed to provide maximum assurance of equipment operability within the network facility environment.</b></p> <p>The Level 3 Criteria is the highest assurance of product operability. Products that meet NEBS Level 3 Criteria are suited for equipment applications, which demand minimal service interruptions over the life span of the equipment. The <i>PANDUIT</i>® <i>FIBERRUNNER</i>® Cable Routing System has successfully passed a range of tests including:</p> <ul style="list-style-type: none"> <li>• Extreme Temperature and Humidity</li> <li>• Operating Temperature and Humidity</li> <li>• Zone 4 Earthquake and Office Vibration</li> <li>• Needle Flame Analysis</li> </ul> |
| <p><b>UL Underwriters Laboratories, Inc.</b></p> <p>Underwriters Laboratories, Inc. is an independent, not for profit safety testing and certification organization based in the United States.</p>   | <p><b>UL 2024A Optical Fiber Cable Routing Assemblies</b></p> <p>Covers, fittings and components construction, flammability rating and marking. The <i>FIBERRUNNER</i>® Cable Routing System has passed test requirements for Riser Rated applications.</p> <p><b>UL V-0 Flammability Rating</b></p> <p>Underwriters Laboratories, Inc. Standards applicable to specified <i>PANDUIT</i>® <i>FIBERRUNNER</i>® Cable Routing System components.</p>  |
| <p><b>TIA Telecommunications Industry Association</b></p> <p>The Telecommunications Industry Association is a leading U.S. non-profit trade association serving the communications and information technology industry. TIA represents providers of communications and information technology products and services for the global marketplace through its core competencies in standard development.</p>               | <p><b>ANSI/TIA-942 Draft 5.0a – Telecommunications Infrastructure Standard for Data Centers ANSI/TIA-569-B Commercial Building Standard for Telecommunications Pathways and Spaces</b></p> <p>Referenced as a method of separating and routing data cable in overhead cable routing applications. The <i>PANDUIT</i>® <i>FIBERRUNNER</i>® Cable Routing System provides pathway components that allow the system to be configured in compliance with these standards.</p>   |



**PANDUIT Corp.**  
Tinley Park, Illinois 60477-3091

For more information  
**Visit us at [www.panduit.com](http://www.panduit.com)**  
Contact Customer Service by email: [cs@panduit.com](mailto:cs@panduit.com)  
or by phone: 800-777-3300

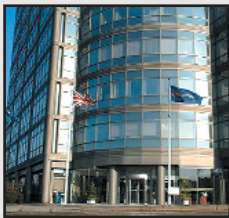

**PANDUIT Europe Ltd.**  
London, UK  
[cs-emea@panduit.com](mailto:cs-emea@panduit.com)  
Phone: 44.20.8601.7200



**PANDUIT Japan**  
Tokyo, Japan  
[cs-japan@panduit.com](mailto:cs-japan@panduit.com)  
Phone: 81.3.3767.7011



**PANDUIT Singapore Pte. Ltd.**  
Republic of Singapore  
[cs-ap@panduit.com](mailto:cs-ap@panduit.com)  
Phone: 65.6379.6700



**PANDUIT Latin America**  
Jalisco, Mexico  
[cs-la@panduit.com](mailto:cs-la@panduit.com)  
Phone: 52.333.777.6000



**PANDUIT Australia Pty. Ltd.**  
Victoria, Australia  
[cs-aus@panduit.com](mailto:cs-aus@panduit.com)  
Phone: 61.3.9794.9020



**PANDUIT Canada**  
Markham, Ontario  
[cs-cdn@panduit.com](mailto:cs-cdn@panduit.com)  
Phone: 800.777.3300

## WORLDWIDE HEADQUARTERS

For a copy of *PANDUIT* product warranties, log on to [www.panduit.com/warranty](http://www.panduit.com/warranty)

© 2007 *PANDUIT* Corp.  
ALL RIGHTS RESERVED  
Printed in the U.S.A.  
Brochure Number **SA-FRCB02**  
1/2007